

# FT1.2 Message Format

decoding a message example:  
received busmon message

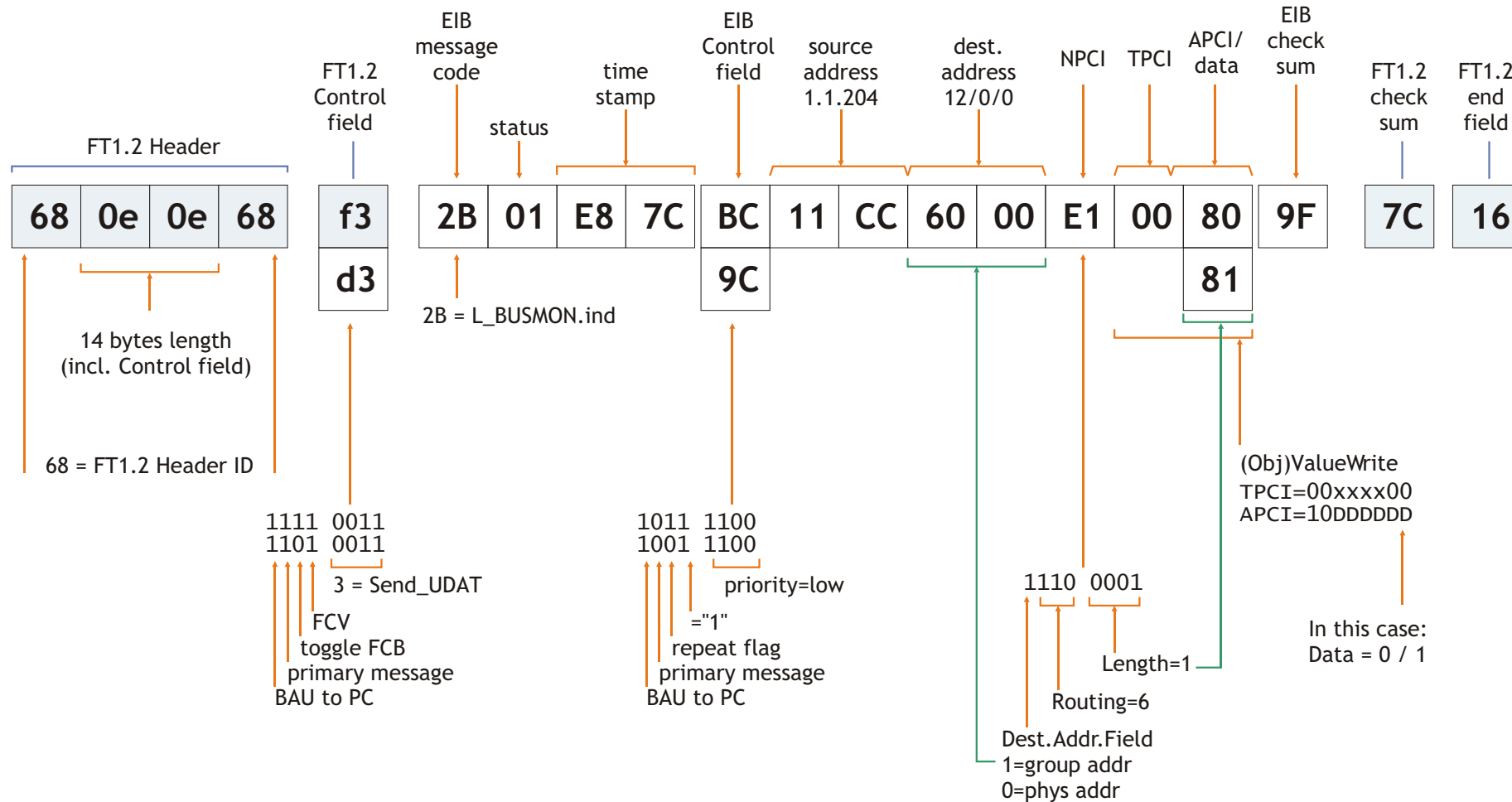

## REMARKS

- since this is a busmon message, it contains also status and time stamp

# FT1.2 Message Format

decoding a message example:  
this is a message sent to a BCU

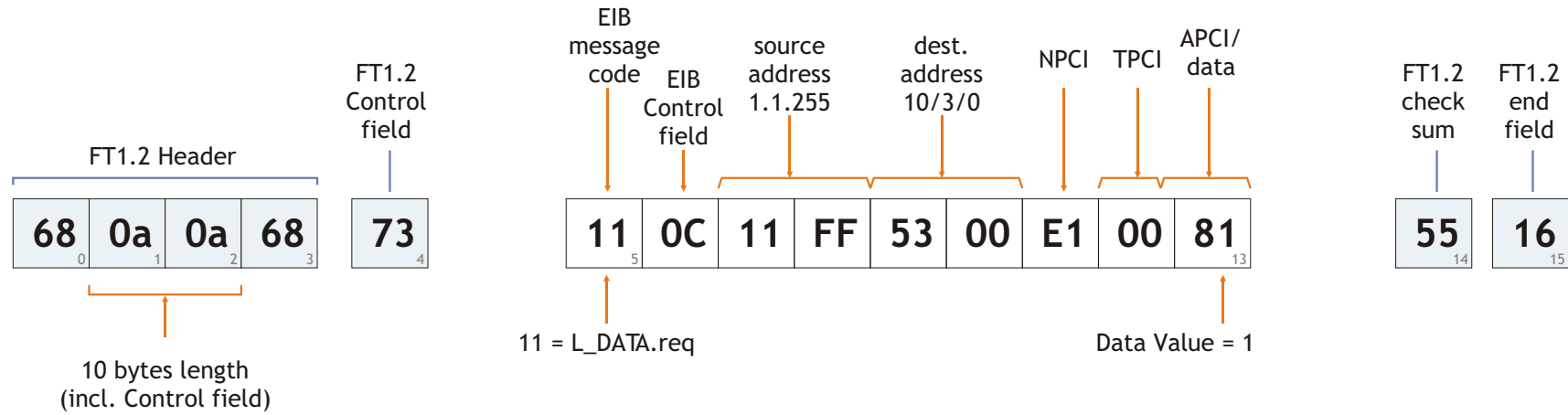

## REMARKS

- the BCU takes the EIB message, adds checksum and transmit the message over the EIB
- the FT1.2 checksum is the LSB of sum of bytes 4 to 13
- the phys. source address of 1.1.255 does not matter, the BCU will replace this with its own phys. address